



PROXIMITY SWITCH P-Prox range



Proximity sensor for:

- Door and hatch open / closed monitoring
- PEEK housing
- Detection without contact
- Approved on helicopters

Mechanical characteristics:

- Material: plastic (PEEK)
- MTBF: 82 000 FH
- Weight: 65g (2.29 oz)
- Operating temperature: -45°C to +85°C (-49°F to +185°F)
- Storage temperature: -55°C to +85°C (-67°F to +185°F)
- Mechanical interface: Thread M12
- Tightening torque 2Nm

Standards:

- Application RTCA / DO-160G, MIL-STD-810
- RoHS, REACH

Target detection:

- Guaranteed actuation: 2 mm (0.11 inch)
- Guaranteed deactuation: 5 mm (0.2 inch)
- Target material: AISI 304
- Target dimension: 10x12, thickness 1 mm

Electrical characteristics:

- Rated voltage: 28 VDC (nominal)
- Max voltage: 32,5 VDC
- Min voltage: 10 VDC
- Output load: 35 mA max.
- Electrical interface: Axial side cable output
- Connector upon request

Dimensions:

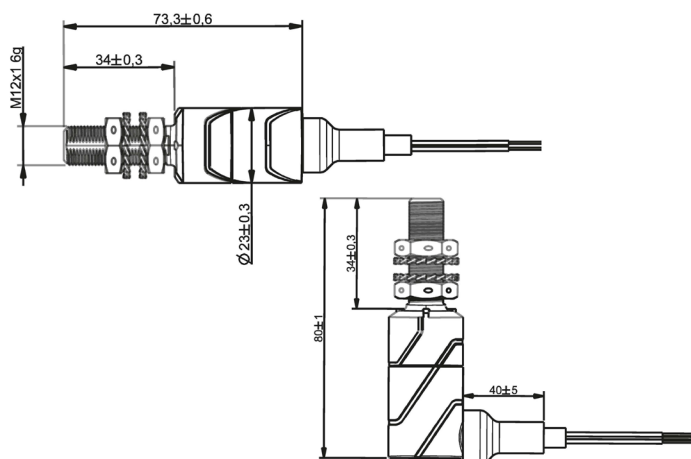

Possible electrical configuration :

