



MLHE/120



LED Ø 120 mm Railway Headlight

- Compact solution
- 2 modes available, steady or blinking
- Optical variants adapted to different operating areas
- Improved lifetime (full LED technology)

Mechanical / Environmental characteristics:

- Operating temperature: - 40°C/+70°C
- Front or rear mounting
- IP65 front and rear
- Shock resistance: IK08
- Plastic protective cover
- Cable connection
- UV resistant
- Salt mist resistance : 480 h
- Bearing angle adjustment at +/-1,5°

Standards:

- Railway application EN 50155
- EMC EN 50121-3-2
- Shock / vibrations EN 61373
- Environment EN 60068, EN 60529
- Fire/smoke EN 45545-2, NFPA 130
- Cable EN 50306-4
- REACH, RoHS

Electrical characteristics:

- Power supply: 24 - 110 Vdc (-30% / +25%)
- Optimized power consumption
- Long service life: 60 000h
- Light status feedback (potential free contact)

Options:

- Light intensities can be adapted on request
- Autonomous flashing mode
- Customized connector and cable length
- Mechanical interface mounting plate

Optical characteristics:

Metro applications in Europe :

- EN 15153-3 § 5.2

Function	Standards	Product features	
	Light intensity (cd)	Light intensity (cd)	Mean consumption (W)+/-20%
Lower full headlight	-	~42 000	~28
Lower dimmed headlight	12 000 - 16 000	~14 000	~10



MLHE/120

Dimensions:

Front mounting

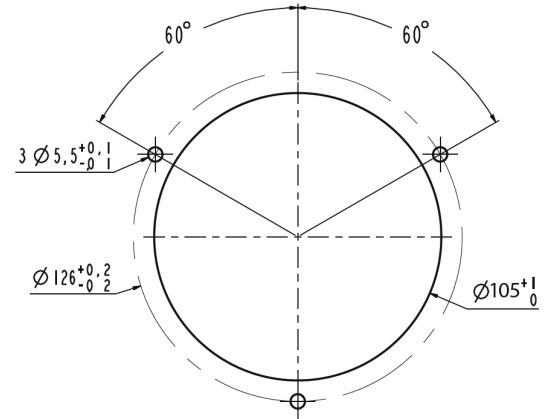
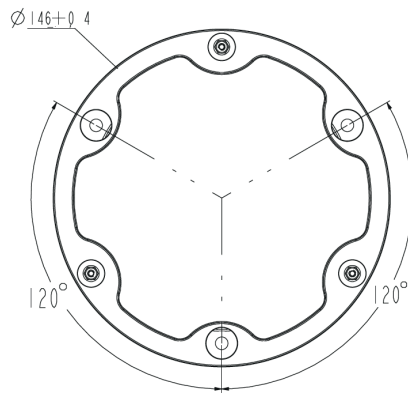
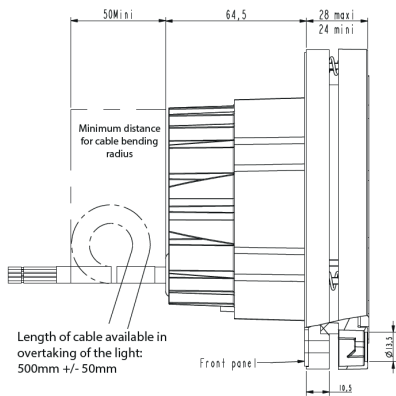

Rear mounting

