



*M-SAFE features

Mechanical characteristics:

- Operating temperature : - 40°C / + 85°C
- Storage conditions : see YNN4091
- Mechanical service life > 3 000 000 operations
- Protection : IP65 external button / IP44 internal button
- Activation force <12N and click! - Motion < 2 mm
- High performance adhesive (on glass)
- Single and double glazing thickness: 3 to 20 mm
- Compatible heat treated glass
- Product thickness = 13.6 mm
- Frame interface angles: 90° standard (other angles adaptable on request)

Luminous characteristics:

- Unlimited choice of backlit pictograms, with color change
- LED colors on request
- Luminous intensity >30 cd/m²

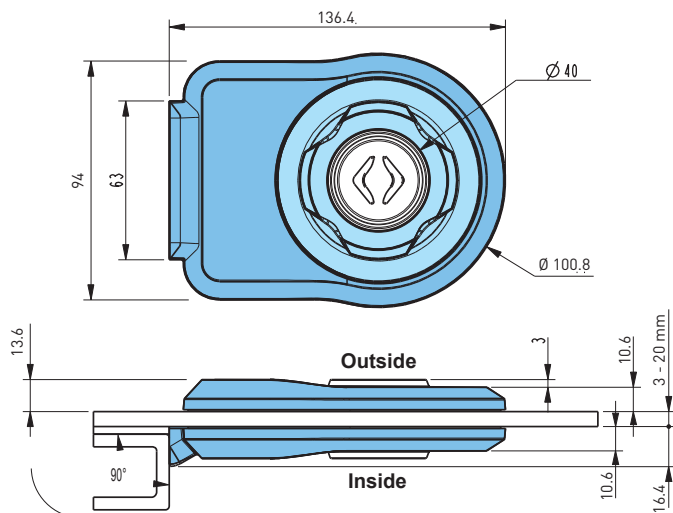

Double or single push button without glass drilling

- **2 switching modes :**
 - Touchless*
 - Pushbutton for visually impaired
- **Antimicrobial surface***
- **Fast assembly bonded on glass**
- **Auto synchronized pushbuttons on glass from 3 to 20mm**

Standards:

- Application EN 14752, TSI PRM, EN16584-2, EN 50155, Decree May 3, 2007
- EMC CISPR25, ECER10, EN50121-3-2
- Environment ISO 16 750, EN 60529, EN 60068 EN 61373
- Fire & smoke ECER118, EN 45545-2
- REACH / ROHS

Electrical characteristics:

- Voltage : standard 24 Vdc (other voltages on request)
- Reverse polarity protection and overvoltage
- Long service life (LED technology)
- Railway & Bus adapted products to respect EMC standards
- Electrical diagram * (example)

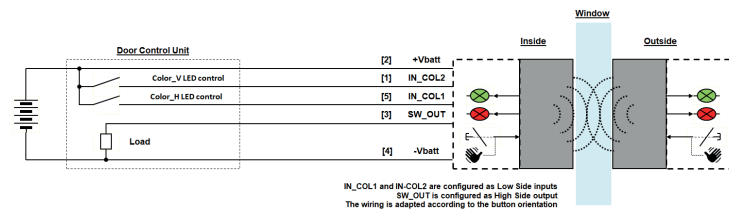

*Others: Please contact us.

Options:

- Extreme temperatures -50°C to +85°C
- Large choice of colors
- Raised pictograms
- Braille
- Cable and connector choice
- Customized electronics
- Customized frame interface angles